



[WWW.MAKOKNGAM.COM](http://WWW.MAKOKNGAM.COM)

## Bilge Pump 500-3M 12V-2.2A

Brand: SEAFLO

Model: Bilge Pump 500-3M 12V-2.2A



### Product Description

1. Heavy duty motors with stainless steel shafts and tough thermoplastic bodies.
2. Totally submersible and ignition protected.
3. To all existing safety standards.
4. Water cooled motors for long life, with anti airlock design and moisture tight seals.
5. Snap-lock strainer base for easy installation and removal, and silent vibration free running
6. Includes comprehensive user manual with installation instructions and wiring diagram

### Application

Typically used in boat hulls / bilges

Bait tanks

Ponds, pools, spas

Other applications where you have to remove water from

Note: These pumps are designed for intermittent use only, NOT designed for continuous use

## How a Bilge Pump Works

Non-automatic bilge pumps offer traditional operation activated by a float or panel switch. Removal of the motor cartridge allows for Easy cleaning of the strainer and impeller in the event that the pump becomes clogged with debris. Electric Submersible Pumps are by far the most popular type of electric Bilge Pumps, submersibles give very high outputs, are cost effective, have low amp draw and are easy to install. They are designed to fit in the lowest part of the bilge and only require discharge pipe work and electricity supply.

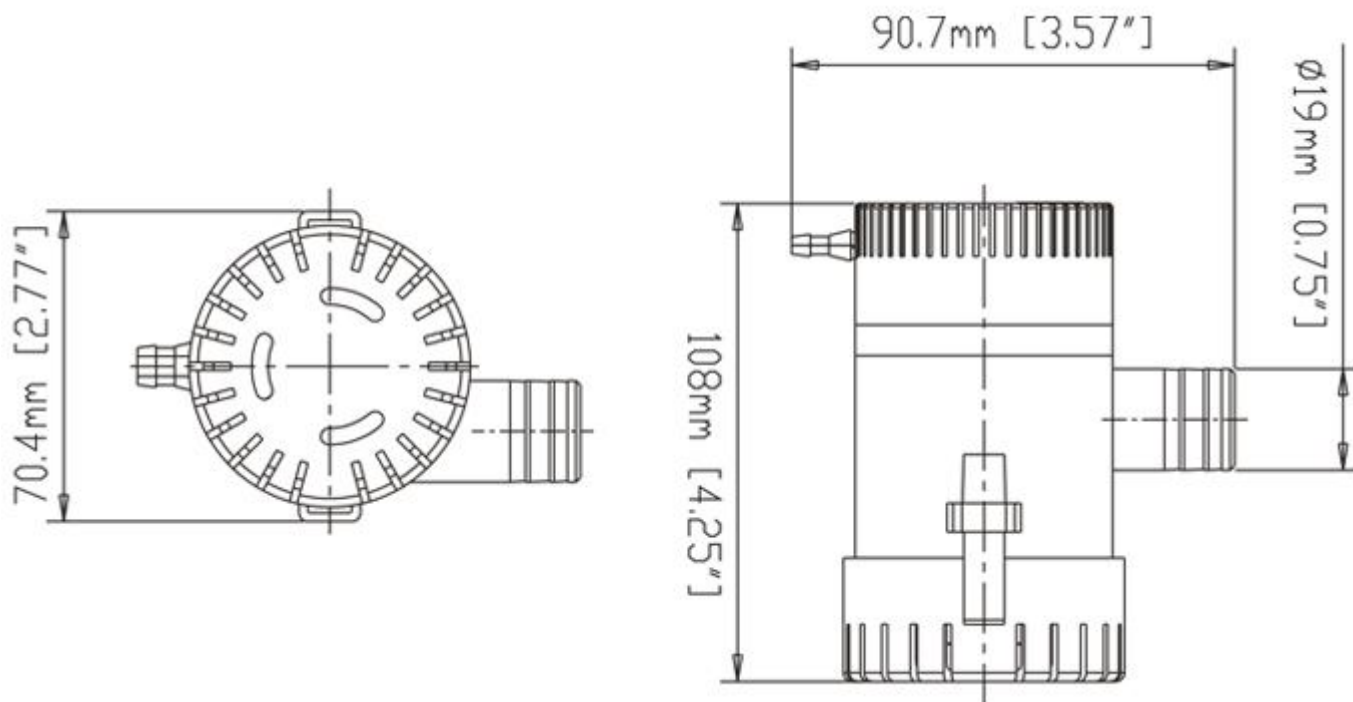

Model	Flow rate	Volts	Current	Discharge Fitting	Wire lead	Delivery Head
SFBP1-G350-01	350GPH	12V	1.8A	19mm/3/4"	1m	3m
SFBP2-G350-01	350GPH	24V	1.0A	19mm/3/4"	1m	3m
<b>SFBP1-G500-01</b>	<b>500GPH</b>	<b>12V</b>	<b>2.2A</b>	<b>19mm/3/4"</b>	<b>1m</b>	<b>3m</b>
SFBP2-G500-01	500GPH	24V	1.2A	19mm/3/4"	1m	3m
SFBP1-G750-01	750GPH	12V	2.5A	19mm/3/4"	1m	4m
SFBP2-G750-01	750GPH	24V	1.5A	19mm/3/4"	1m	4m
SFBP1-G1100-01	1100GPH	12V	3.0A	29mm/1-1/8"	1m	4m
SFBP2-G1100-01	1100GPH	24V	1.5A	29mm/1-1/8"	1m	4m